

MAXQ615 Evaluation Kit

Evaluates: MAXQ615

General Description

The MAXQ615 evaluation kit (EV kit) provides a proven platform for conveniently evaluating the capabilities of the MAXQ615 low-power, 16-bit, RISC microcontroller targeted for battery-powered applications. The EV kit includes a MAXQ615 EV kit board, example software, USB-to-JTAG interface board, 10-pin JTAG interface cable, and a standard A-to-mini-B USB cable for connecting to a personal computer. The EV kit board, which provides pin headers providing access to the processor's I/O port pins, a 5V power-supply input, pushbutton switches for user input, and an on-board SPI ADC and I²C temperature sensor for demonstration purposes. The EV kit provides a complete, functional system ideal for developing and debugging applications as well as evaluating the overall capabilities of the MAXQ615 RISC processor.

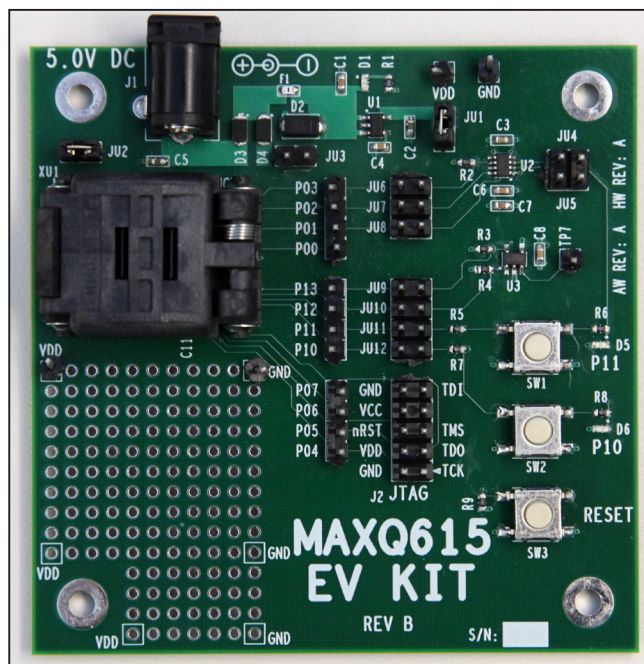

Figure 1. MAXQ615 Evaluation Kit Board

[Ordering Information](#) appears at end of data sheet.

Features

- ◆ Easily Loads and Debugs Code Using Supplied JTAG Board
- ◆ JTAG Interface Provides In-Application Debugging Features
 - ◇ Step-by-Step Execution Tracing
 - ◇ Breakpointing by Code Address, Data Memory Address, or Register Access
 - ◇ Data Memory or Register Content View and Edit
- ◆ On-Board 3.3V Voltage Regulator
- ◆ On-Board DS1775 I²C Temperature Sensor
- ◆ On-Board MAX1118 SPI ADC
- ◆ Two User-Input Pushbutton Switches with Paired Indicator LEDs (Connected to GPIO)
- ◆ Prototyping Area
- ◆ (Optional) +5V Regulated, Minimum 250mA Capacity, Center Post Positive Power Supply with 2.5mm Jack. Models that have been used in the past include CUI Inc. model DPR050030-P6P-SZ and V Infinity model EPS050100-P6P. If the EV kit is powered through the USB-to-JTAG adapter (through the 5V supply provided on the JTAG cable), then this power supply is not needed.

EV Kit Contents

- ◆ MAXQ615 EV Kit Board with Either Socketed MAXQ615 (XU1) or Soldered MAXQ615 (U4)
- ◆ USB-to-JTAG Adapter Board
- ◆ 2 x 5-Pin Connector Ribbon Cable (0.1in spacing) for JTAG Programming
- ◆ Standard A-to-Mini-B USB interface Cable
- ◆ MAXQ615 EV Kit CD (includes the MAXQ615 IC data sheet and user's guide; MAXQ615 EV kit quick start guide, data sheet, and schematics; application notes; utilities and configuration files; and example programs including source code). Go to www.maxim-ic.com/evkitsoftware to download the latest version of the EV kit CD.

MAXQ615 Evaluation Kit

Evaluates: MAXQ615

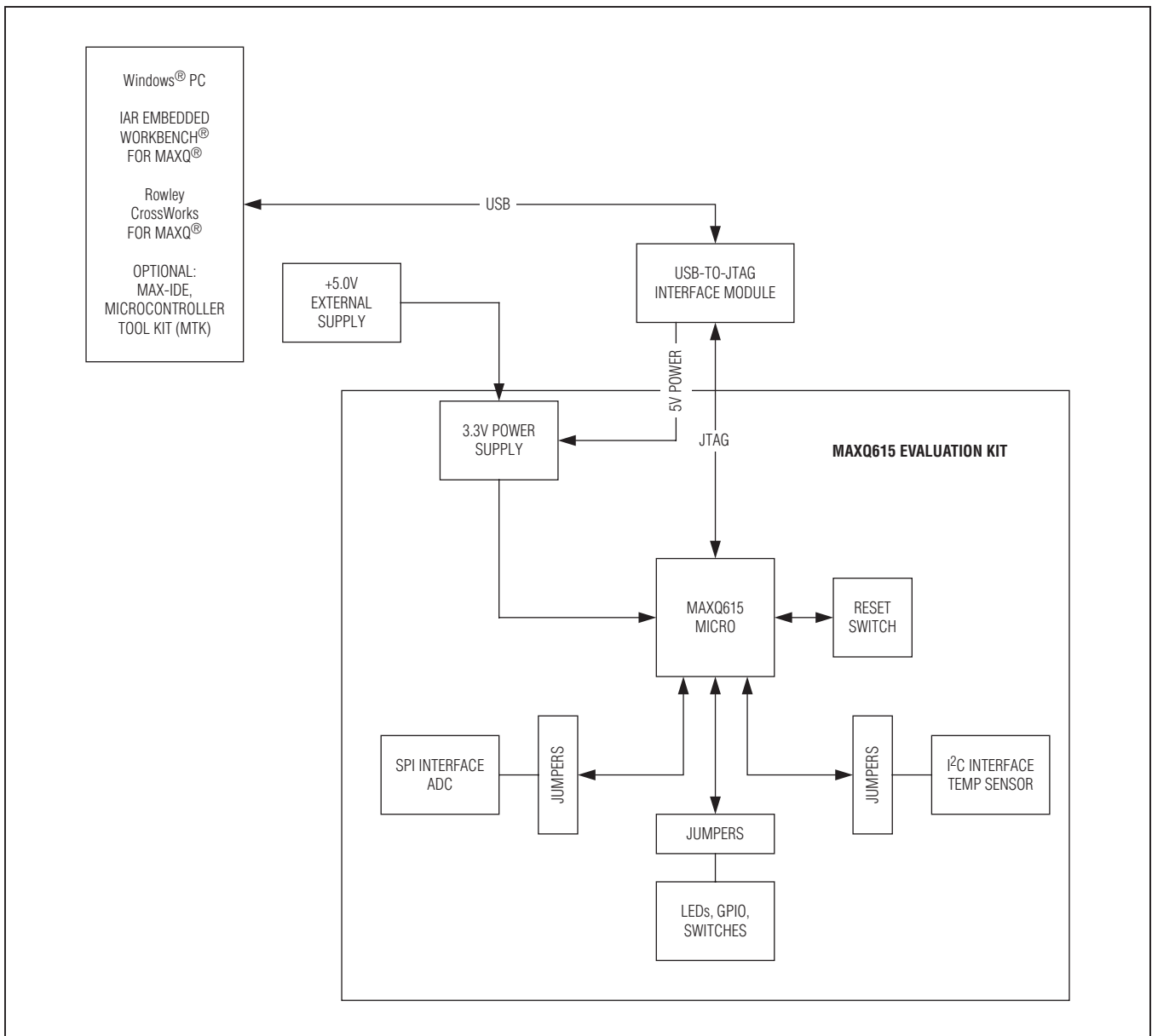

Figure 2. MAXQ615 EV Kit System Block Diagram

Windows is a registered trademark of Microsoft Corp.

IAR Embedded Workbench is a registered trademark of IAR Systems AB.

MAXQ is a registered trademark of Maxim Integrated Products, Inc.

MAXQ615 Evaluation Kit

Evaluates: MAXQ615

Component List

DESIGNATION	QTY	DESCRIPTION
C1, C7, C10–C12, C14	6	1 μ F, 16V ceramic capacitors (0603)
C2	1	2.2 μ F, 6.3V ceramic capacitor (0603)
C3, C6, C8, C9, C13	5	100nF, 16V ceramic capacitors (0603)
C4	1	10nF, 25V ceramic capacitor (0603)
C5	1	4.7 μ F, 10V ceramic capacitor (0603)
D1, D5, D6	3	Surface-mount, 570nm green LEDs (0603) LG L29K-G2J1-24-Z
D2	1	SMAJ5.0A (DO-214AC, SMA)
D3, D4	2	CGRM4001-G (SOD-123F)
F1	1	Fuse 200mA resettable (0603) MF-FSMF020X-2
J1	1	2.5mm power jack, through-hole mount, center post positive
J2	1	2 x 5 header pins, 0.1in spacing
JU1–JU12	12	2 x 2 header pins, 0.1in spacing
MH1–MH4	4	Mounting holes
R1	1	845 Ω \pm 1%, 1/10W SMD resistor (0603)
R2, R9	2	10k Ω \pm 1%, 1/10W SMD resistors (0603)

DESIGNATION	QTY	DESCRIPTION
R3, R4	2	1.8k Ω \pm 1%, 1/10W SMD resistors (0603)
R5, R7	2	110 Ω \pm 1%, 1/10W SMD resistors (0603)
R6, R8	2	402 Ω \pm 1%, 1/10W SMD resistors (0603)
SW1–SW3	2	SPST normally open pushbutton switches, 6mm, B3S-1002
TP1–TP21	21	Test points
U1	1	150mA linear regulator (5 SOT23) Maxim MAX8877EUK33+
U2	1	Serial 2-channel ADC (8 SOT23) Maxim MAX1118
U3	1	I ² C temperature sensor (5 SOT23) Maxim DS1775
U4	1	Microcontroller (16 TQFN-EP) Maxim MAXQ615-F00+
XU1	1	Microcontroller socket Maxim MAXQ615-F00+
—	0	PCB: MAXQ615 EV KIT

Detailed Description

This EV kit should be used with the following documents:

- MAXQ615 IC data sheet
- MAXQ615 user's guide
- MAXQ615 EV kit data sheet

These documents are included on the MAXQ615 EV kit CD, along with additional documentation and application notes. For the latest versions of the documents listed above, go to www.maxim-ic.com/MAXQ615.

This document includes full schematics for the EV kit. Descriptions of the major sections and functions of the board follows.

Power Supply

The MAXQ615 EV kit can be powered in several ways. The board can be powered from the USB-to-JTAG adapter. The adapter provides a +5V DC supply. From this, an

on-board linear regulator (U1) regulates the +3.3V VDD power rail that is used by the MAXQ615.

If the MAXQ615 kit is "free-running," that is, if you are running an application that has been previously loaded into the MAXQ615, and you do not need to use the loader or debugger, the board may be powered by a 5V DC wall supply connected to plug J1. The supply must be center post positive, DC 5V regulated, with a 250mA minimum capacity.

By removing jumper JU1 and connecting a power supply in its place, it is also possible to power the MAXQ615 from a DC bench supply or other regulated power source. In this case, any power-supply voltage compatible with the device(s) that will be powered may be used; refer to the MAXQ615 IC data sheet for more details on the allowable range for the power supply.

Reset Pushbutton

Pushbutton SW3 can be used to manually reset the MAXQ615.

MAXQ615 Evaluation Kit

Evaluates: MAXQ615

Serial ADC

The EV kit board includes a MAX1118 2-channel serial ADC (U2). By connecting the appropriate jumpers, the ADC can be connected to the MAXQ615, and is used to demonstrate the microcontroller's SPI communication interface. Each of the two ADC channels can be connected to the cathode of an on-board LED, and can be used to measure the voltage drop across the LED. The CD included with this EV kit includes sample code to demonstrate how to interact with the ADC.

I²C Temperature Sensor

The EV kit board includes a DS1775 I²C temperature sensor (U3). By connecting the appropriate jumpers, the temperature sensor can be connected to the MAXQ615, and is used to demonstrate the microcontroller's I²C communication interface. The CD included with this EV kit includes sample code to demonstrate how to interact with the temperature sensor.

GPIO Pushbuttons and Indicator LEDs

The two pushbuttons on the EV kit board can be connected to the MAXQ615 GPIO pins P1.0 and P1.1 by closing the associated jumper. See [Table 1](#) for a description of the jumpers. If the pushbutton is pressed, it will pull the attached port pin low. The label indicating which port pin is tied to the switch is found on the board next to the switch. Switch SW2 pulls pin P1.0 (P10 label) low and switch SW1 pulls pin P1.1 low.

The indicator LEDs (D5 and D6) next to each switch can also be connected to the port pin by closing the associated jumper (as detailed in the jumper table). The LED will be illuminated if either the GPIO pin connected to it is driven low, or the pushbutton switch is pressed.

Jumper Function List

[Table 1](#) details the functions of the configurable jumpers on the EV kit board. Settings in the table marked with "*" indicate jumper placements that should be used for most normal operation (default settings).

Table 1. Jumper Functions

JUMPER	SETTING	EFFECT OF SETTING
JU1	Open	No on-board supply is connected to the V _{DD} rail. To operate the EV kit, an external bench supply must be connected to JU1.2 or one of the V _{DD} test points. Refer to the MAXQ615 IC data sheet for acceptable operating range information for the V _{DD} supply.
	*Closed	The +3.3V output from the on-board linear regulator (U1) is connected to the V _{DD} rail. This supply will be used to power the MAXQ615 (as long as JU2 is closed), as well as the demo components U2 and U3 and the LEDs D5 and D6.
JU2	Open	No power is provided to the MAXQ615. This position should only be used when connecting a current meter between JU2.1 and JU2.2 to measure power consumption by the MAXQ615.
	*Closed	The V _{DD} pin on the MAXQ615 is connected to the on-board V _{DD} power supply rail.
JU3	Open	The 5V pin on the JTAG cable is not connected to the on-board linear regulator supply input. If this position is used, then either a 5V external supply must be connected to J1 or a bench supply must be connected to JU1.2 or a V _{DD} test point (with JU1 open)
	Closed	The MAXQ615 EV kit may be powered directly through the USB-to-JTAG adapter's 5V supply (from the USB bus supply)
JU4	Open	No effect
	Closed	The channel 1 input (CH1) on the ADC U2 is connected between LED D5 and R6 (see the EV kit schematic). This can be used to measure the diode drop across D5, for demonstration purposes.
JU5	Open	No effect
	Closed	The channel 0 input (CH0) on the ADC U2 is connected between LED D6 and R8 (refer to the kit schematic). This can be used to measure the diode drop across D6, for demonstration purposes.
JU6	Open	No effect
	Closed	The "start conversion on falling edge" pin on the MAX1118 (U2) is connected to pin P0.3 on the MAXQ615. Refer to the MAX1118 IC data sheet for more information on initiating A/D conversions and reading conversion results.

MAXQ615 Evaluation Kit

Evaluates: MAXQ615

Table 1. Jumper Functions (continued)

JUMPER	SETTING	EFFECT OF SETTING
JU7	Open	No effect
	Closed	The DOUT pin on the MAX1118 is connected to the SPI 0 interface MISO pin (P0.1) on the MAXQ615.
JU8	Open	No effect
	Closed	The SCLK pin on the MAX1118 is connected to the SPI 0 interface pin SCLK (P0.2) on the MAXQ615.
JU9	Open	No effect
	Closed	Connects the SDA pin on the I ² C temperature sensor (DS1775, U3) to the I ² C SDA pin (P1.3) on the MAXQ615. Also connects the I ² C bus pullup resistor (R3) to the SDA pin on the MAXQ615.
JU10	Open	No effect
	Closed	Connects the SCL pin on the I ² C temperature sensor (DS1775, U3) to the I ² C SCL pin (P1.2) on the MAXQ615. Also connects the I ² C bus pullup resistor (R4) to the SCL pin on the MAXQ615.
JU11	Open	No effect
	Closed	Allows the green LED D5 to be controlled using the port pin P1.1 (driving the port pin low lights the LED). Also, pressing SW1 will both drive P1.1 low and cause the LED to light.
JU12	Open	No effect
	Closed	Allows the green LED D6 to be controlled using the port pin P1.0 (driving the port pin low lights the LED). Also, pressing SW2 will both drive P1.0 low and cause the LED to light.

MAXQ615 Evaluation Kit

Evaluates: **MAXQ615**

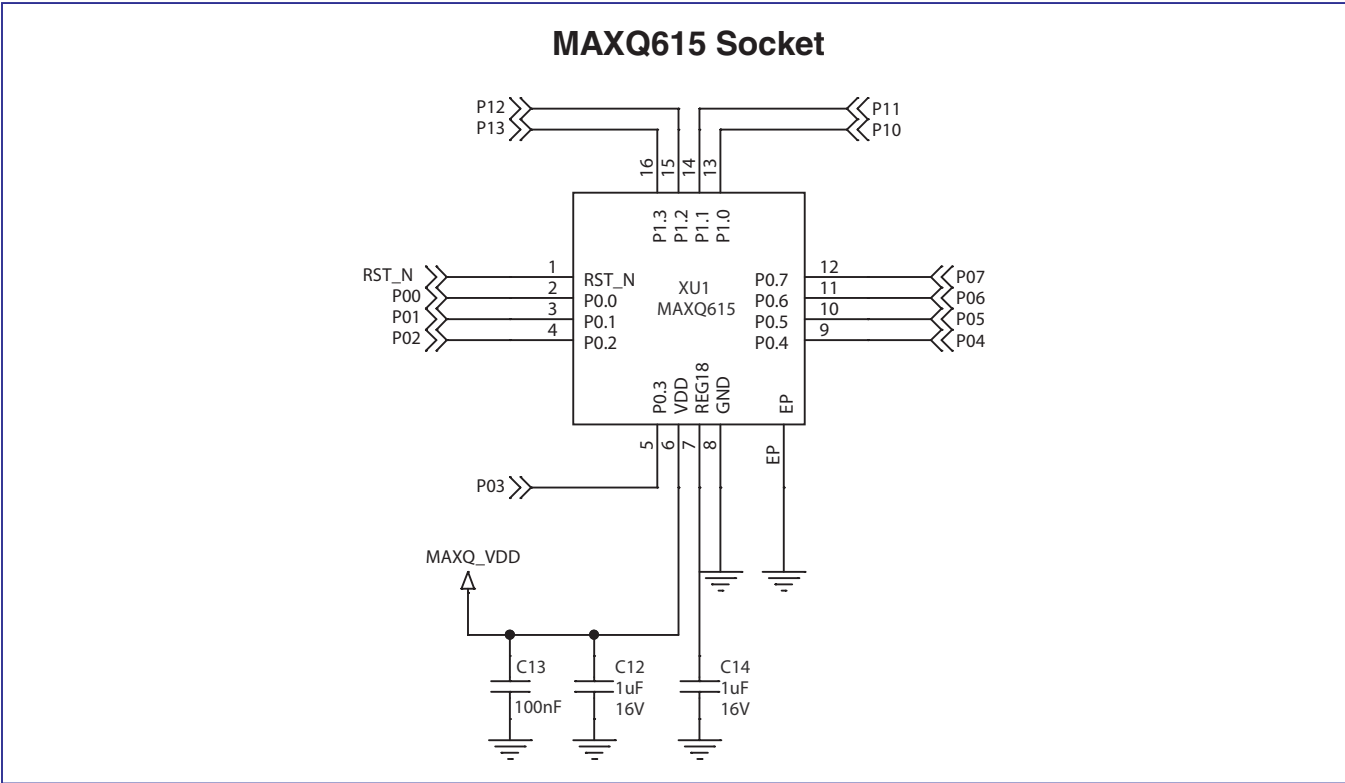

Figure 4. MAXQ615 EV Kit Schematics (Sheet 2 of 2)

MAXQ615 Evaluation Kit

Evaluates: MAXQ615

Ordering Information

PART	TYPE
MAXQ615-KIT#	EV Kit

#Denotes a RoHS-compliant device that may include lead(Pb) that is exempt under the RoHS requirements.

MAXQ615 Evaluation Kit

Evaluates: **MAXQ615**

Revision History

REVISION NUMBER	REVISION DATE	DESCRIPTION	PAGES CHANGED
0	7/12	Initial release	—

Maxim cannot assume responsibility for use of any circuitry other than circuitry entirely embodied in a Maxim product. No circuit patent licenses are implied. Maxim reserves the right to change the circuitry and specifications without notice at any time.

Maxim Integrated Products, Inc. 160 Rio Robles, San Jose, CA 95134 USA 1-408-601-1000 _____ 9